

Appendix C

Federal Aviation Regulations,
Part 77



APPENDIX C

Federal Aviation Regulations, Part 77

Part 77 — Objects Affecting Navigable Airspace

Subpart A General

- 77.1 Scope.
- 77.2 Definition of terms.
- 77.3 Standards.
- 77.5 Kinds of objects affected.

Subpart B Notice of Construction or Alteration

- 77.11 Scope.
- 77.13 Construction or alteration requiring notice.
- 77.15 Construction or alteration not requiring notice.
- 77.17 Form and time of notice.
- 77.19 Acknowledgment of notice.

Subpart C Obstruction Standards

- 77.21 Scope.
- 77.23 Standards for determining obstructions.
- 77.25 Civil airport imaginary surfaces.
- 77.27 [Reserved]
- 77.28 Military airport imaginary surfaces.
- 77.29 Airport imaginary surfaces for heliports.

Subpart D Aeronautical Studies of Effect of Proposed Construction on Navigable Airspace

- 77.31 Scope.
- 77.33 Initiation of studies.
- 77.35 Aeronautical studies.
- 77.37 Discretionary review.
- 77.39 Effective period of determination of no hazard.

Subpart E Rules of Practice for Hearings under Subpart D

- 77.41 Scope.
- 77.43 Nature of hearing.
- 77.45 Presiding officer.
- 77.47 Legal officer.
- 77.49 Notice of hearing.
- 77.51 Parties to the hearing.
- 77.53 Prehearing conference.
- 77.55 Examination of witnesses.
- 77.57 Evidence.
- 77.59 Subpoenas of witnesses and exhibits.
- 77.61 Revision of construction or alteration proposal.
- 77.63 Record of hearing.
- 77.65 Recommendations by parties.
- 77.67 Final decision of the Administrator.
- 77.69 Limitations on appearance and representation.

Subpart F Establishment of Antenna Farm Areas

- 77.71 Scope.
- 77.73 General provisions.
- 77.75 Establishment of antenna farm areas.

Authority: 49 U.S.C. 106(g), 40103, 40113-40114, 44502, 44701, 44718, 46101-46102, 46104.
Source: Docket No. 1882, 30 FR 1839, Feb. 10, 1965, unless otherwise noted.

Subpart A — General

Sec. 77.1 Scope.

This part:

- (a) Establishes standards for determining obstructions in navigable airspace;
 - (b) Sets forth the requirements for notice to the Administrator of certain proposed construction or alteration;
 - (c) Provides for aeronautical studies of obstructions to air navigation, to determine their effect on the safe and efficient use of airspace;
 - (d) Provides for public hearings on the hazardous effect of proposed construction or alteration on air navigation; and
 - (e) Provides for establishing antenna farm areas.
-

Sec. 77.2 Definition of Terms.

For the purpose of this part:

“Airport available for public use” means an airport that is open to the general public with or without a prior request to use the airport.

“A seaplane base” is considered to be an airport only if its sea lanes are outlined by visual markers.

“Nonprecision instrument runway” means a runway having an existing instrument approach procedure utilizing air navigation facilities with only horizontal guidance, or area type navigation equipment, for which a straight- in nonprecision instrument approach procedure has been approved, or planned, and for which no precision approach facilities are planned, or indicated on an FAA planning document or military service military airport planning document.

“Precision instrument runway” means a runway having an existing instrument approach procedure utilizing an Instrument Landing System (ILS), or a Precision Approach Radar (PAR). It also means a runway for which a precision approach system is planned and is so indicated by an FAA approved airport layout plan; a military service approved military airport layout plan; any other FAA planning document, or military service military airport planning document.

“Utility runway” means a runway that is constructed for and intended to be used by propeller driven aircraft of 12,500 pounds maximum gross weight and less.

“Visual runway” means a runway intended solely for the operation of aircraft using visual approach procedures, with no straight-in instrument approach procedure and no instrument designation indicated on an FAA approved airport layout plan, a military service approved military airport layout plan, or by any planning document submitted to the FAA by competent authority.

[Amdt. 77-5, 33 FR 5256, Apr. 2, 1968, as amended by Amdt. 77-9, 36 FR 5969, Apr. 1, 1971]

Sec. 77.3 Standards.

- (a) The standards established in this part for determining obstructions to air navigation are used by the Administrator in:
- (1) Administering the Federal-aid Airport Program and the Surplus Airport Program;
 - (2) Transferring property of the United States under section 16 of the Federal Airport Act;
 - (3) Developing technical standards and guidance in the design and construction of airports; and
 - (4) Imposing requirements for public notice of the construction or alteration of any structure where notice will promote air safety.
- (b) The standards used by the Administrator in the establishment of flight procedures and aircraft operational limitations are not set forth in this part but are contained in other publications of the Administrator.

[Doc. No. 1882, 30 FR 1839, Feb. 10, 1965, as amended by Amdt. 77-9, 36 FR 5970, Apr. 1, 1971]

Sec. 77.5 Kinds of Objects Affected.

This part applies to:

- (a) Any object of natural growth, terrain, or permanent or temporary construction or alteration, including equipment or materials used therein, and apparatus of a permanent or temporary character; and
- (b) Alteration of any permanent or temporary existing structure by a change in its height (including appurtenances), or lateral dimensions, including equipment or materials used therein.

Subpart B — Notice of Construction or Alteration

Sec. 77.11 Scope.

- (a) This subpart requires each person proposing any kind of construction or alteration described in Sec. 77.13(a) to give adequate notice to the Administrator. It specifies the locations and dimensions of the construction or alteration for which notice is required and prescribes the form and manner of the notice. It also requires supplemental notices 48 hours before the start and upon the completion of certain construction or alteration that was the subject of a notice under Sec. 77.13(a).
- (b) Notices received under this subpart provide a basis for:
- (1) Evaluating the effect of the construction or alteration on operational procedures and proposed operational procedures;
 - (2) Determinations of the possible hazardous effect of the proposed construction or alteration on air navigation;
 - (3) Recommendations for identifying the construction or alteration in accordance with the current Federal Aviation Administration Advisory Circular AC 70/7460-1 entitled "Obstruction Marking and Lighting," which is available without charge from the Department of Transportation, Distribution Unit, TAD 484.3, Washington, D.C. 20590.
 - (4) Determining other appropriate measures to be applied for continued safety of air navigation; and
 - (5) Charting and other notification to airmen of the construction or alteration.

(Sec. 6, 80 Stat. 937, 49 U.S.C. 1655
 [Doc. No. 1882, 30 FR 1839, Feb. 10, 1965, as amended by Amdt. 77-8, 33 FR 18614, Dec. 17, 1968;
 Amdt. 77-10, 37 FR 4705, Mar. 4, 1972]

Sec. 77.13 Construction or Alteration Requiring Notice.

- (a) Except as provided in Sec. 77.15, each sponsor who proposes any of the following construction or alteration shall notify the Administrator in the form and manner prescribed in Sec. 77.17:
- (1) Any construction or alteration of more than 200 feet in height above the ground level at its site.
 - (2) Any construction or alteration of greater height than an imaginary surface extending outward and upward at one of the following slopes:
 - (i) 100 to 1 for a horizontal distance of 20,000 feet from the nearest point of the nearest runway of each airport specified in paragraph (a)(5) of this section with at least one runway more than 3,200 feet in actual length, excluding heliports.

- (ii) 50 to 1 for a horizontal distance of 10,000 feet from the nearest point of the nearest runway of each airport specified in paragraph (a)(5) of this section with its longest runway no more than 3,200 feet in actual length, excluding heliports.
 - (iii) 25 to 1 for a horizontal distance of 5,000 feet from the nearest point of the nearest landing and takeoff area of each heliport specified in paragraph (a)(5) of this section.
- (3) Any highway, railroad, or other traverse way for mobile objects, of a height which, if adjusted upward 17 feet for an Interstate Highway that is part of the National System of Military and Interstate Highways where overcrossings are designed for a minimum of 17 feet vertical distance, 15 feet for any other public roadway, 10 feet or the height of the highest mobile object that would normally traverse the road, whichever is greater, for a private road, 23 feet for a railroad, and for a waterway or any other traverse way not previously mentioned, an amount equal to the height of the highest mobile object that would normally traverse it, would exceed a standard of paragraph (a) (1) or (2) of this section.
- (4) When requested by the FAA, any construction or alteration that would be in an instrument approach area (defined in the FAA standards governing instrument approach procedures) and available information indicates it might exceed a standard of Subpart C of this part.
- (5) Any construction or alteration on any of the following airports (including heliports):
 - (i) An airport that is available for public use and is listed in the Airport Directory of the current Airman's Information Manual or in either the Alaska or Pacific Airman's Guide and Chart Supplement.
 - (ii) An airport under construction, that is the subject of a notice or proposal on file with the Federal Aviation Administration, and, except for military airports, it is clearly indicated that that airport will be available for public use.
 - (iii) An airport that is operated by an armed force of the United States.
- (b) Each sponsor who proposes construction or alteration that is the subject of a notice under paragraph (a) of this section and is advised by an FAA regional office that a supplemental notice is required shall submit that notice on a prescribed form to be received by the FAA regional office at least 48 hours before the start of the construction or alteration.
- (c) Each sponsor who undertakes construction or alteration that is the subject of a notice under paragraph (a) of this section shall, within 5 days after that construction or alteration reaches its greatest height, submit a supplemental notice on a prescribed form to the FAA regional office having jurisdiction over the region involved, if—
 - (1) The construction or alteration is more than 200 feet above the surface level of its site; or
 - (2) An FAA regional office advises him that submission of the form is required.

[Amdt. 77-5, 33 FR 5256, Apr. 2, 1968, as amended by Amdt. 77-9, 36 FR 5970, Apr. 1, 1971; Amdt. 77-10, 37 FR 4705, Mar. 4, 1972]

Sec. 77.15 Construction or Alteration Not Requiring Notice.

No person is required to notify the Administrator for any of the following construction or alteration:

- (a) Any object that would be shielded by existing structures of a permanent and substantial character or by natural terrain or topographic features of equal or greater height, and would be located in the congested area of a city, town, or settlement where it is evident beyond all reasonable doubt that the structure so shielded will not adversely affect safety in air navigation.
- (b) Any antenna structure of 20 feet or less in height except one that would increase the height of another antenna structure.
- (c) Any air navigation facility, airport visual approach or landing aid, aircraft arresting device, or meteorological device, of a type approved by the Administrator, or an appropriate military service on military airports, the location and height of which is fixed by its functional purpose.
- (d) Any construction or alteration for which notice is required by any other FAA regulation.

[Doc. No. 1882, 30 FR 1839, Feb. 10, 1965, as amended by Amdt. 77-5, 33 FR 5257, Apr. 2, 1968; Amdt. 77-9, 36 FR 5970, Apr. 1, 1971]

Sec. 77.17 Form and Time of Notice.

- (a) Each person who is required to notify the Administrator under Sec. 77.13(a) shall send one executed form set (four copies) of FAA Form 7460-1, Notice of Proposed Construction or Alteration, to the Manager, Air Traffic Division, FAA Regional Office having jurisdiction over the area within which the construction or alteration will be located. Copies of FAA Form 7460-1 may be obtained from the headquarters of the Federal Aviation Administration and the regional offices.
- (b) The notice required under Sec. 77.13(a) (1) through (4) must be submitted at least 30 days before the earlier of the following dates:
 - (1) The date the proposed construction or alteration is to begin.
 - (2) The date an application for a construction permit is to be filed. However, a notice relating to proposed construction or alteration that is subject to the licensing requirements of the Federal Communications Act may be sent to FAA at the same time the application for construction is filed with the Federal Communications Commission, or at any time before that filing.
- (c) A proposed structure or an alteration to an existing structure that exceeds 2,000 feet in height above the ground will be presumed to be a hazard to air navigation and to result in an inefficient utilization of airspace and the applicant has the burden of overcoming that presumption. Each notice submitted under the pertinent provisions of this Part 77 proposing a structure in excess of 2,000 feet above ground, or an alteration that will make an existing structure exceed that height, must contain a detailed showing, directed to meeting this

burden. Only in exceptional cases, where the FAA concludes that a clear and compelling showing has been made that it would not result in an inefficient utilization of the airspace and would not result in a hazard to air navigation, will a determination of no hazard be issued.

- (d) In the case of an emergency involving essential public services, public health, or public safety that requires immediate construction or alteration, the 30-day requirement in paragraph (b) of this section does not apply and the notice may be sent by telephone, telegraph, or other expeditious means, with an executed FAA Form 7460-1 submitted within 5 days thereafter. Outside normal business hours, emergency notices by telephone or telegraph may be submitted to the nearest FAA Flight Service Station.
- (e) Each person who is required to notify the Administrator by paragraph (b) or (c) of Sec. 77.13, or both, shall send an executed copy of FAA Form 117-1, Notice of Progress of Construction or Alteration, to the Manager, Air Traffic Division, FAA Regional Office having jurisdiction over the area involved.

(Sec. 6, 80 Stat. 937, 49 U.S.C. 1655

[Doc. No. 1882, 30 FR 1839, Feb. 10, 1965, as amended by Amdt. 77-2, 31 FR 9449, July 12, 1966; Amdt. 77-8, 33 FR 18614, Dec. 17, 1968; Amdt. 77-10, 37 FR 4705, Mar. 4, 1972; Amdt. 77-11, 54 FR 39292, Sept. 25, 1989]

Sec. 77.19 Acknowledgment of Notice.

- (a) The FAA acknowledges in writing the receipt of each notice submitted under Sec. 77.13(a).
- (b) If the construction or alteration proposed in a notice is one for which lighting or marking standards are prescribed in the FAA Advisory Circular AC 70/7460-1, entitled "Obstruction Marking and Lighting," the acknowledgment contains a statement to that effect and information on how the structure should be marked and lighted in accordance with the manual.
- (c) The acknowledgment states that an aeronautical study of the proposed construction or alteration has resulted in a determination that the construction or alteration:
 - (1) Would not exceed any standard of Subpart C and would not be a hazard to air navigation;
 - (2) Would exceed a standard of Subpart C but would not be a hazard to air navigation; or
 - (3) Would exceed a standard of Subpart C and further aeronautical study is necessary to determine whether it would be a hazard to air navigation, that the sponsor may request within 30 days that further study, and that, pending completion of any further study, it is presumed the construction or alteration would be a hazard to air navigation.

[Doc. No. 1882, 30 FR 1839, Feb. 10, 1965, as amended by Amdt. 77-4, 32 FR 12997, Sept. 13, 1967; Amdt. 77-5, 33 FR 5257, Apr. 2, 1968

Subpart C — Obstruction Standards

Sec. 77.21 Scope.

- (a) This subpart establishes standards for determining obstructions to air navigation. It applies to existing and proposed manmade objects, objects of natural growth, and terrain. The standards apply to the use of navigable airspace by aircraft and to existing air navigation facilities, such as an air navigation aid, airport, Federal airway, instrument approach or departure procedure, or approved off-airway route. Additionally, they apply to a planned facility or use, or a change in an existing facility or use, if a proposal therefore is on file with the Federal Aviation Administration or an appropriate military service on the date the notice required by Sec. 77.13(a) is filed.
- (b) At those airports having defined runways with specially prepared hard surfaces, the primary surface for each such runway extends 200 feet beyond each end of the runway. At those airports having defined strips or pathways that are used regularly for the taking off and landing of aircraft and have been designated by appropriate authority as runways, but do not have specially prepared hard surfaces, each end of the primary surface for each such runway shall coincide with the corresponding end of the runway. At those airports, excluding seaplane bases, having a defined landing and takeoff area with no defined pathways for the landing and taking off of aircraft, a determination shall be made as to which portions of the landing and takeoff area are regularly used as landing and takeoff pathways. Those pathways so determined shall be considered runways and an appropriate primary surface as defined in Sec. 77.25(c) will be considered as being longitudinally centered on each runway so determined, and each end of that primary surface shall coincide with the corresponding end of that runway.
- (c) The standards in this subpart apply to the effect of construction or alteration proposals upon an airport if, at the time of filing of the notice required by Sec. 77.13(a), that airport is—
 - (1) Available for public use and is listed in the Airport Directory of the current Airman's Information Manual or in either the Alaska or Pacific Airman's Guide and Chart Supplement; or
 - (2) A planned or proposed airport or an airport under construction, that is the subject of a notice or proposal on file with the Federal Aviation Administration, and, except for military airports, it is clearly indicated that that airport will be available for public use; or,
 - (3) An airport that is operated by an armed force of the United States.

[Doc. No. 1882, 30 FR 1839, Feb. 10, 1965, as amended by Amdt. 77-5, 33 FR 5257, Apr. 2, 1968; Amdt. 77-9, 36 FR 5970, Apr. 1, 1971]

Sec. 77.23 Standards for Determining Obstructions.

- (a) An existing object, including a mobile object, is, and a future object would be an obstruction to air navigation if it is of greater height than any of the following heights or surfaces:
- (1) A height of 500 feet above ground level at the site of the object.
 - (2) A height that is 200 feet above ground level or above the established airport elevation, whichever is higher, within 3 nautical miles of the established reference point of an airport, excluding heliports, with its longest runway more than 3,200 feet in actual length, and that height increases in the proportion of 100 feet for each additional nautical mile of distance from the airport up to a maximum of 500 feet.
 - (3) A height within a terminal obstacle clearance area, including an initial approach segment, a departure area, and a circling approach area, which would result in the vertical distance between any point on the object and an established minimum instrument flight altitude within that area or segment to be less than the required obstacle clearance.
 - (4) A height within an en route obstacle clearance area, including turn and termination areas, of a Federal airway or approved off-airway route, that would increase the minimum obstacle clearance altitude.
 - (5) The surface of a takeoff and landing area of an airport or any imaginary surface established under Sec. 77.25, Sec. 77.28, or Sec. 77.29. However, no part of the take-off or landing area itself will be considered an obstruction.
- (b) Except for traverse ways on or near an airport with an operative ground traffic control service, furnished by an air traffic control tower or by the airport management and coordinated with the air traffic control service, the standards of paragraph (a) of this section apply to traverse ways used or to be used for the passage of mobile objects only after the heights of these traverse ways are increased by:
- (1) Seventeen feet for an Interstate Highway that is part of the National System of Military and Interstate Highways where overcrossings are designed for a minimum of 17 feet vertical distance.
 - (2) Fifteen feet for any other public roadway.
 - (3) Ten feet or the height of the highest mobile object that would normally traverse the road, whichever is greater, for a private road.
 - (4) Twenty-three feet for a railroad, and,
 - (5) For a waterway or any other traverse way not previously mentioned, an amount equal to the height of the highest mobile object that would normally traverse it.

[Amdt. 77-9, 36 FR 5970, Apr. 1, 1971]

Sec. 77.25 Civil Airport Imaginary Surfaces.

The following civil airport imaginary surfaces are established with relation to the airport and to each runway. The size of each such imaginary surface is based on the category of each runway according to the type of approach available or planned for that runway. The slope and dimensions of the approach surface applied to each end of a runway are determined by the most precise approach existing or planned for that runway end.

- (a) **Horizontal surface.** A horizontal plane 150 feet above the established airport elevation, the perimeter of which is constructed by swinging arcs of specified radii from the center of each end of the primary surface of each runway of each airport and connecting the adjacent arcs by lines tangent to those arcs. The radius of each arc is:
 - (1) 5,000 feet for all runways designated as utility or visual;
 - (2) 10,000 feet for all other runways. The radius of the arc specified for each end of a runway will have the same arithmetical value. That value will be the highest determined for either end of the runway. When a 5,000-foot arc is encompassed by tangents connecting two adjacent 10,000-foot arcs, the 5,000-foot arc shall be disregarded on the construction of the perimeter of the horizontal surface.
- (b) **Conical surface.** A surface extending outward and upward from the periphery of the horizontal surface at a slope of 20 to 1 for a horizontal distance of 4,000 feet.
- (c) **Primary surface.** A surface longitudinally centered on a runway. When the runway has a specially prepared hard surface, the primary surface extends 200 feet beyond each end of that runway; but when the runway has no specially prepared hard surface, or planned hard surface, the primary surface ends at each end of that runway. The elevation of any point on the primary surface is the same as the elevation of the nearest point on the runway centerline. The width of a primary surface is:
 - (1) 250 feet for utility runways having only visual approaches.
 - (2) 500 feet for utility runways having nonprecision instrument approaches.
 - (3) For other than utility runways the width is:
 - (i) 500 feet for visual runways having only visual approaches.
 - (ii) 500 feet for nonprecision instrument runways having visibility minimums greater than three-fourths statute mile.
 - (iii) 1,000 feet for a nonprecision instrument runway having a nonprecision instrument approach with visibility minimums as low as three-fourths of a statute mile, and for precision instrument runways. The width of the primary surface of a runway will be that width prescribed in this section for the most precise approach existing or planned for either end of that runway.
- (d) **Approach surface.** A surface longitudinally centered on the extended runway centerline and extending outward and upward from each end of the primary surface. An approach surface is applied to each end of each runway based upon the type of approach available or planned for that runway end.

- (1) The inner edge of the approach surface is the same width as the primary surface and it expands uniformly to a width of:
 - (i) 1,250 feet for that end of a utility runway with only visual approaches;
 - (ii) 1,500 feet for that end of a runway other than a utility runway with only visual approaches;
 - (iii) 2,000 feet for that end of a utility runway with a nonprecision instrument approach;
 - (iv) 3,500 feet for that end of a nonprecision instrument runway other than utility, having visibility minimums greater than three-fourths of a statute mile;
 - (v) 4,000 feet for that end of a nonprecision instrument runway, other than utility, having a nonprecision instrument approach with visibility minimums as low as three-fourths statute mile; and
 - (vi) 16,000 feet for precision instrument runways.
 - (2) The approach surface extends for a horizontal distance of:
 - (i) 5,000 feet at a slope of 20 to 1 for all utility and visual runways;
 - (ii) 10,000 feet at a slope of 34 to 1 for all nonprecision instrument runways other than utility; and,
 - (iii) 10,000 feet at a slope of 50 to 1 with an additional 40,000 feet at a slope of 40 to 1 for all precision instrument runways.
 - (3) The outer width of an approach surface to an end of a runway will be that width prescribed in this subsection for the most precise approach existing or planned for that runway end.
- (e) Transitional surface. These surfaces extend outward and upward at right angles to the runway centerline and the runway centerline extended at a slope of 7 to 1 from the sides of the primary surface and from the sides of the approach surfaces. Transitional surfaces for those portions of the precision approach surface which project through and beyond the limits of the conical surface, extend a distance of 5,000 feet measured horizontally from the edge of the approach surface and at right angles to the runway centerline.

[Amdt. 77-9, 36 FR 5970, Apr. 1, 1971; 36 FR 6741, Apr. 8, 1971]

Sec. 77.27 [Reserved]

Sec. 77.28 Military airport imaginary surfaces.

- (a) Related to airport reference points. These surfaces apply to all military airports. For the purposes of this section a military airport is any airport operated by an armed force of the United States.
- (1) Inner horizontal surface. A plane is oval in shape at a height of 150 feet above the established airfield elevation. The plane is constructed by scribing an arc with a radius of 7,500 feet about the centerline at the end of each runway and interconnecting these arcs with tangents.
 - (2) Conical surface. A surface extending from the periphery of the inner horizontal surface outward and upward at a slope of 20 to 1 for a horizontal distance of 7,000 feet to a height of 500 feet above the established airfield elevation.
 - (3) Outer horizontal surface. A plane, located 500 feet above the established airfield elevation, extending outward from the outer periphery of the conical surface for a horizontal distance of 30,000 feet.
- (b) Related to runways. These surfaces apply to all military airports.
- (1) Primary surface. A surface located on the ground or water longitudinally centered on each runway with the same length as the runway. The width of the primary surface for runways is 2,000 feet. However, at established bases where substantial construction has taken place in accordance with a previous lateral clearance criteria, the 2,000-foot width may be reduced to the former criteria.
 - (2) Clear zone surface. A surface located on the ground or water at each end of the primary surface, with a length of 1,000 feet and the same width as the primary surface.
 - (3) Approach clearance surface. An inclined plane, symmetrical about the runway centerline extended, beginning 200 feet beyond each end of the primary surface at the centerline elevation of the runway end and extending for 50,000 feet. The slope of the approach clearance surface is 50 to 1 along the runway centerline extended until it reaches an elevation of 500 feet above the established airport elevation. It then continues horizontally at this elevation to a point 50,000 feet from the point of beginning. The width of this surface at the runway end is the same as the primary surface, it flares uniformly, and the width at 50,000 is 16,000 feet.
 - (4) Transitional surfaces. These surfaces connect the primary surfaces, the first 200 feet of the clear zone surfaces, and the approach clearance surfaces to the inner horizontal surface, conical surface, outer horizontal surface or other transitional surfaces. The slope of the transitional surface is 7 to 1 outward and upward at right angles to the runway centerline.

[Doc. No. 1882, 30 FR 1839, Feb. 10, 1965, as amended by Amdt. 77-1, 30 FR 6713, May 18, 1965; Amdt. 77-9, 36 FR 5971, Apr. 1, 1971]

Sec. 77.29 Airport Imaginary Surfaces for Heliports.

- (a) Heliport primary surface. The area of the primary surface coincides in size and shape with the designated take-off and landing area of a heliport. This surface is a horizontal plane at the elevation of the established heliport elevation.
- (b) Heliport approach surface. The approach surface begins at each end of the heliport primary surface with the same width as the primary surface, and extends outward and upward for a horizontal distance of 4,000 feet where its width is 500 feet. The slope of the approach surface is 8 to 1 for civil heliports and 10 to 1 for military heliports.
- (c) Heliport transitional surfaces. These surfaces extend outward and upward from the lateral boundaries of the heliport primary surface and from the approach surfaces at a slope of 2 to 1 for a distance of 250 feet measured horizontally from the centerline of the primary and approach surfaces.

[Doc. No. 1882, 30 FR 1839, Feb. 10, 1965, as amended by Amdt. 77-9, 36 FR 5971, Apr. 1, 1971; 36 FR 6741, Apr. 8, 1971]

Subpart D — Aeronautical Studies of Effect of Proposed Construction on Navigable Airspace

Sec. 77.31 Scope.

- (a) This subpart applies to the conduct of aeronautical studies of the effect of proposed construction or alteration on the use of air navigation facilities or navigable airspace by aircraft. In the aeronautical studies, present and future IFR and VFR aeronautical operations and procedures are reviewed and any possible changes in those operations and procedures and in the construction proposal that would eliminate or alleviate the conflicting demands are ascertained.
- (b) The conclusion of a study made under this subpart is normally a determination as to whether the specific proposal studied would be a hazard to air navigation.

[Doc. No. 1882, 30 FR 1839, Feb. 10, 1965, as amended by Amdt. 77-6, 33 FR 10843, July 31, 1968]

Sec. 77.33 Initiation of Studies.

- (a) An aeronautical study is conducted by the FAA:
 - (1) Upon the request of the sponsor or any construction or alteration for which a notice is submitted under Subpart B of this part, unless that construction or alteration would be located within an antenna farm area established under Subpart F of this part; or
 - (2) Whenever the FAA determines it appropriate.

[Doc. No. 1882, 30 FR 1839, Feb. 10, 1965, as amended by Amdt. 77-4, 32 FR 12997, Sept. 13, 1967]

Sec. 77.35 Aeronautical Studies.

- (a) The Regional Manager, Air Traffic Division of the region in which the proposed construction or alteration would be located, or his designee, conducts the aeronautical study of the effect of the proposal upon the operation of air navigation facilities and the safe and efficient utilization of the navigable airspace. This study may include the physical and electromagnetic radiation effect the proposal may have on the operation of an air navigation facility.
- (b) To the extent considered necessary, the Regional Manager, Air Traffic Division or his designee:
 - (1) Solicits comments from all interested persons;
 - (2) Explores objections to the proposal and attempts to develop recommendations for adjustment of aviation requirements that would accommodate the proposed construction or alteration;

- (3) Examines possible revisions of the proposal that would eliminate the exceeding of the standards in Subpart C of this part; and
 - (4) Convenes a meeting with all interested persons for the purpose of gathering all facts relevant to the effect of the proposed construction or alteration on the safe and efficient utilization of the navigable airspace.
- (c) The Regional Manager, Air Traffic Division or his designee issues a determination as to whether the proposed construction or alteration would be a hazard to air navigation and sends copies to all known interested persons. This determination is final unless a petition for review is granted under Sec. 77.37.
- (d) If the sponsor revises his proposal to eliminate exceeding of the standards of Subpart C of this part, or withdraws it, the Regional Manager, Air Traffic Division, or his designee, terminates the study and notifies all known interested persons.

[Doc. No. 1882, 30 FR 1839, Feb. 10, 1965, as amended by Amdt. 77-6, 33 FR 10843, July 31, 1968; Amdt. 77-11, 54 FR 39292, Sept. 25, 1989]

Sec. 77.37 Discretionary Review.

- (a) The sponsor of any proposed construction or alteration or any person who stated a substantial aeronautical objection to it in an aeronautical study, or any person who has a substantial aeronautical objection to it but was not given an opportunity to state it, may petition the Administrator, within 30 days after issuance of the determination under Sec. 77.19 or Sec. 77.35 or revision or extension of the determination under Sec. 77.39(c), for a review of the determination, revision, or extension. This paragraph does not apply to any acknowledgment issued under Sec. 77.19(c)(1).
- (b) The petition must be in triplicate and contain a full statement of the basis upon which it is made.
- (c) The Administrator examines each petition and decides whether a review will be made and, if so, whether it will be:
- (1) A review on the basis of written materials, including study of a report by the Regional Manager, Air Traffic Division of the aeronautical study, briefs, and related submissions by any interested party, and other relevant facts, with the Administrator affirming, revising, or reversing the determination issued under Sec. 77.19, Sec. 77.35 or Sec. 77.39(c); or
 - (2) A review on the basis of a public hearing, conducted in accordance with the procedures prescribed in Subpart E of this part.

[Doc. No. 1882, 30 FR 1839, Feb. 10, 1965, as amended by Amdt. 77-3, 32 FR 6970, May 6, 1967; Amdt. 77-11, 54 FR 39292, Sept. 25, 1989]

Sec. 77.39 Effective Period of Determination of No Hazard.

- (a) Unless it is otherwise extended, revised, or terminated, each final determination of no hazard made under this subpart or Subpart B or E of this part expires 18 months after its effective date, regardless of whether the proposed construction or alteration has been started, or on the date the proposed construction or alteration is abandoned, whichever is earlier.
- (b) In any case, including a determination to which paragraph (d) of this section applies, where the proposed construction or alteration has not been started during the applicable period by actual structural work, such as the laying of a foundation, but not including excavation, any interested person may, at least 15 days before the date the final determination expires, petition the FAA official who issued the determination to:
 - (1) Revise the determination based on new facts that change the basis on which it was made; or
 - (2) Extend its effective period.
- (c) The FAA official who issued the determination reviews each petition presented under paragraph (b) of this section, and revises, extends, or affirms the determination as indicated by his findings.
- (d) In any case in which a final determination made under this subpart or Subpart B or E of this part relates to proposed construction or alteration that may not be started unless the Federal Communications Commission issues an appropriate construction permit, the effective period of each final determination includes—
 - (1) The time required to apply to the Commission for a construction permit, but not more than 6 months after the effective date of the determination; and
 - (2) The time necessary for the Commission to process the application except in a case where the Administrator determines a shorter effective period is required by the circumstances.
- (e) If the Commission issues a construction permit, the final determination is effective until the date prescribed for completion of the construction. If the Commission refuses to issue a construction permit, the final determination expires on the date of its refusal.

[Doc. No. 1882, 30 FR 1839, Feb. 10, 1965, as amended by Amdt. 77-5, 33 FR 5257, Apr. 2, 1968]

Subpart E — Rules of Practice for Hearings Under Subpart D

Sec. 77.41 Scope.

This subpart applies to hearings held by the FAA under Titles I, III, and X of the Federal Aviation Act of 1958 (49 U.S.C. Subchapters I, III, and X), on proposed construction or alteration that affects the use of navigable airspace.

Sec. 77.43 Nature of Hearing.

Sections 4, 5, 7, and 8 of the Administrative Procedure Act (5 U.S.C. 1003, 1004, 1006, and 1007) do not apply to hearings held on proposed construction or alteration to determine its effect on the safety of aircraft and the efficient use of navigable airspace because those hearings are fact-finding in nature. As a fact-finding procedure, each hearing is nonadversary and there are no formal pleadings or adverse parties.

Sec. 77.45 Presiding Officer.

- (a) If, under Sec. 79.37, the Administrator grants a public hearing on any proposed construction or alteration covered by this part, the Director, Air Traffic Operations Service designates an FAA employee to be the presiding officer at the hearing.
- (b) The presiding officer may:
 - (1) Give notice of the date and location of the hearing and any prehearing conference that may be held;
 - (2) Administer oaths and affirmations;
 - (3) Examine witnesses;
 - (4) Issue subpoenas and take depositions or have them taken;
 - (5) Obtain, in the form of a public record, all pertinent and relevant facts relating to the subject matter of the hearing;
 - (6) Rule, with the assistance of the legal officer, upon the admissibility of evidence;
 - (7) Regulate the course and conduct of the hearing; and
 - (8) Designate parties to the hearing and revoke those designations.

[Doc. No. 1882, 30 FR 1839, Feb. 10, 1965, as amended by Amdt. 77-11, 54 FR 39292, Sept. 25, 1989]

Sec. 77.47 Legal Officer.

The Chief Counsel designates a member of his staff to serve as legal officer at each hearing under this subpart. The legal officer may examine witnesses and assist and advise the presiding officer on questions of evidence or other legal questions arising during the hearing.

[Doc. No. 1882, 30 FR 1839, Feb. 10, 1965, as amended at 38 FR 26444, Sept. 17, 1973]

Sec. 77.49 Notice of Hearing.

In designating a time and place for a hearing under this subpart the presiding officer considers the needs of the FAA and the convenience of the parties and witnesses. The time and place of each hearing is published in the "Notices" section of the Federal Register before the date of the hearing, unless the notice is impractical or unnecessary.

Sec. 77.51 Parties to the Hearing.

The presiding officer designates the following as parties to the hearing—

- (a) The proponent of the proposed construction or alteration.
 - (b) Those persons whose activities would be substantially affected by the proposed construction or alteration.
-

Sec. 77.53 Prehearing Conference.

- (a) The presiding officer may, in his discretion, hold a prehearing conference with the parties to the hearing and the legal officer before the hearing.
- (b) At the direction of the presiding officer, each party to a prehearing conference shall submit a brief written statement of the evidence he intends to provide through his witnesses and by questioning other witnesses at the hearing, and shall provide enough copies of the statement so that the presiding officer may keep three for the FAA and give one to each other party.
- (c) At the prehearing conference, the presiding officer reduces and simplifies the subject matter of the hearing so far as possible and advises the parties of the probable order of presenting the evidence.

Sec. 77.55 Examination of Witnesses.

- (a) Each witness at a hearing under this subpart shall, after being sworn by the presiding officer, give his testimony under oath.
 - (b) The party for whom a witness, other than an employee of the FAA, is testifying shall examine that witness. After that examination, other parties to the hearing may examine the witness, in the order fixed by the presiding officer. The presiding officer and the legal officer may then examine the witness. The presiding officer may grant any party an additional opportunity to examine any witness, if that party adequately justifies the additional examination.
 - (c) The legal officer examines each FAA employee who is a witness, before the other parties examine him. After that examination, the order prescribed in paragraph (b) of this section applies. An FAA employee may testify only as to facts within his personal knowledge and the application of FAA regulations, standards, and policies.
-

Sec. 77.57 Evidence.

- (a) The presiding officer receives all testimony and exhibits that are relevant to the issues of the hearing. So far as possible, each party shall submit enough copies of his exhibits that the presiding officer may keep three copies for the FAA and give one to each other party.
 - (b) The presiding officer excludes any testimony that is irrelevant, unduly repetitious, or consists of statements made during an aeronautical study in an effort to reconcile or compromise aviation or construction or alteration requirements. A party to the hearing may object to the admission of evidence only on the ground that it is irrelevant.
-

Sec. 77.59 Subpoenas of Witnesses and Exhibits.

- (a) The presiding officer of a hearing may issue subpoenas for any witness or exhibit that he determines may be material and relevant to the issues of the hearing. So far as possible, each party to the hearing shall provide the witnesses and exhibits that he intends to present at the hearing.
 - (b) If any party to the hearing is unable to provide his necessary witnesses and exhibits, he shall advise the presiding officer far enough in advance that the presiding officer can determine whether he should issue subpoenas for the desired witnesses or exhibits.
-

Sec. 77.61 Revision of Construction or Alteration Proposal.

- (a) The sponsor of any proposed construction or alteration covered by this part may revise his proposal at any time before or during the hearing. If he revises it, the presiding officer decides whether the revision affects the proposal to the extent that he should send it to the Administrator for a redetermination of the need for a hearing.

-
- (b) If the presiding officer decides that it does not need to be resubmitted to the Administrator, he advises the parties of the revised proposal and takes the action necessary to allow all parties to effectively participate in the hearing on the revised proposal. Without limiting his discretion, the presiding officer may recess and reconvene the hearing, or hold another prehearing conference.
-

Sec. 77.63 Record of Hearing.

- (a) Each hearing is recorded verbatim by an official reporter under an FAA contract. The transcript, and all exhibits, become a part of the record of the hearing.
- (b) Any person may buy a copy of the transcript of the hearing from the reporter at the price fixed for it.
- (c) The presiding officer may allow any party to withdraw an original document if he submits authenticated copies of it.
- (d) Any person may buy, from the FAA, photostatic copies of any exhibit by paying the copying costs.
- (e) A change in the official transcript of a hearing may be made only if it involves an error of substance. Any recommendation to correct the transcript must be filed with the presiding officer within 5 days after the hearing closes. The presiding officer reviews each request for a correction to the extent he considers appropriate and shall make any revisions that he finds appropriate as a result of that review.
-

Sec. 77.65 Recommendations by Parties.

Within 20 days after the mailing of the record of hearing by the official reporter, or as otherwise directed by the presiding officer, each party may submit to the presiding officer five copies of his recommendations for a final decision to be made by the Administrator.

Sec. 77.67 Final Decision of the Administrator.

After reviewing the evidence relevant to the questions of fact in a hearing, including the official transcript and the exhibits, the Administrator resolves all these questions, based on the weight of evidence, and makes his determination, stating the basis and reasons for it. He then issues an appropriate order to be served on each of the parties.

Sec. 77.69 *Limitations on Appearance and Representation.*

- (a) A former officer or employee of the FAA may not appear on behalf of, or represent, any party before the FAA in connection with any matter to which this part applies, if he considered or passed on that matter while he was an officer or employee of the FAA.
- (b) A person appearing before the FAA on any matter to which this part applies may not, in connection with that appearance, knowingly accept assistance from, or share fees with, any person who is prohibited by paragraph (a) of this section, from appearing himself on that matter.
- (c) A former official or employee of the FAA may not, within 6 months after he ceases to be such an officer or employee, appear before the FAA on behalf of, or represent, any party in connection with any proceeding that was pending under this part while he was an officer or employee of the FAA, unless he obtains written consent from an appropriate officer of the FAA, based on a verified showing that he did not personally consider the matter concerned or gain particular knowledge of it while he was an officer or employee of the FAA.

Subpart F — Establishment of Antenna Farm Areas

Sec. 77.71 Scope.

- (a) This subpart establishes antenna farm areas in which antenna structures may be grouped to localize their effect on the use of navigable airspace.
 - (b) It is the policy of the FAA to encourage the use of antenna farms and the single structure-multiple antenna concept for radio and television towers whenever possible. In considering proposals for establishing antenna farm areas, it considers as far as possible the revision of aeronautical procedures and operations to accommodate antenna structures that will fulfill broadcasting requirements.
-

Sec. 77.73 General Provisions.

- (a) An antenna farm area consists of a specified geographical location with established dimensions of area and height, where antenna towers with a common impact on aviation may be grouped. Each such area is established by appropriate rule making action.
- (b) Each proposal for an antenna farm area is evaluated on the basis of its effect on the use of navigable airspace. The views of the Federal Communications Commission are requested on the effect that each establishment of an antenna farm area would have on its statutory responsibilities. Any views submitted by it are fully considered before the antenna farm concerned is established. If the Commission advises that the establishment of any proposed antenna farm area would interfere with its statutory responsibility, the proposed area is not established.
- (c) The establishment of an antenna farm area is considered whenever it is proposed by:
 - (1) The FAA;
 - (2) The Federal Communications Commission;
 - (3) The sponsor of a proposed antenna tower; or
 - (4) Any other person having a substantial interest in a proposed antenna tower.

[Doc. No. 1882, 30 FR 1839, Feb. 10, 1965, as amended by Amdt. 77-10, 37 FR 4705, Mar. 4, 1972]

Sec. 77.75 Establishment of Antenna Farm Areas.

The airspace areas described in the following sections of this subpart are established as antenna farm areas.

Note: Sections 77.77 through 77.1100 reserved for descriptions of antenna farm areas.

14 CFR Part 77 * Amendment 77-12 * Dec. 28, 1995.

**FIGURE C-1
FAR PART 77 IMAGINARY SURFACES**

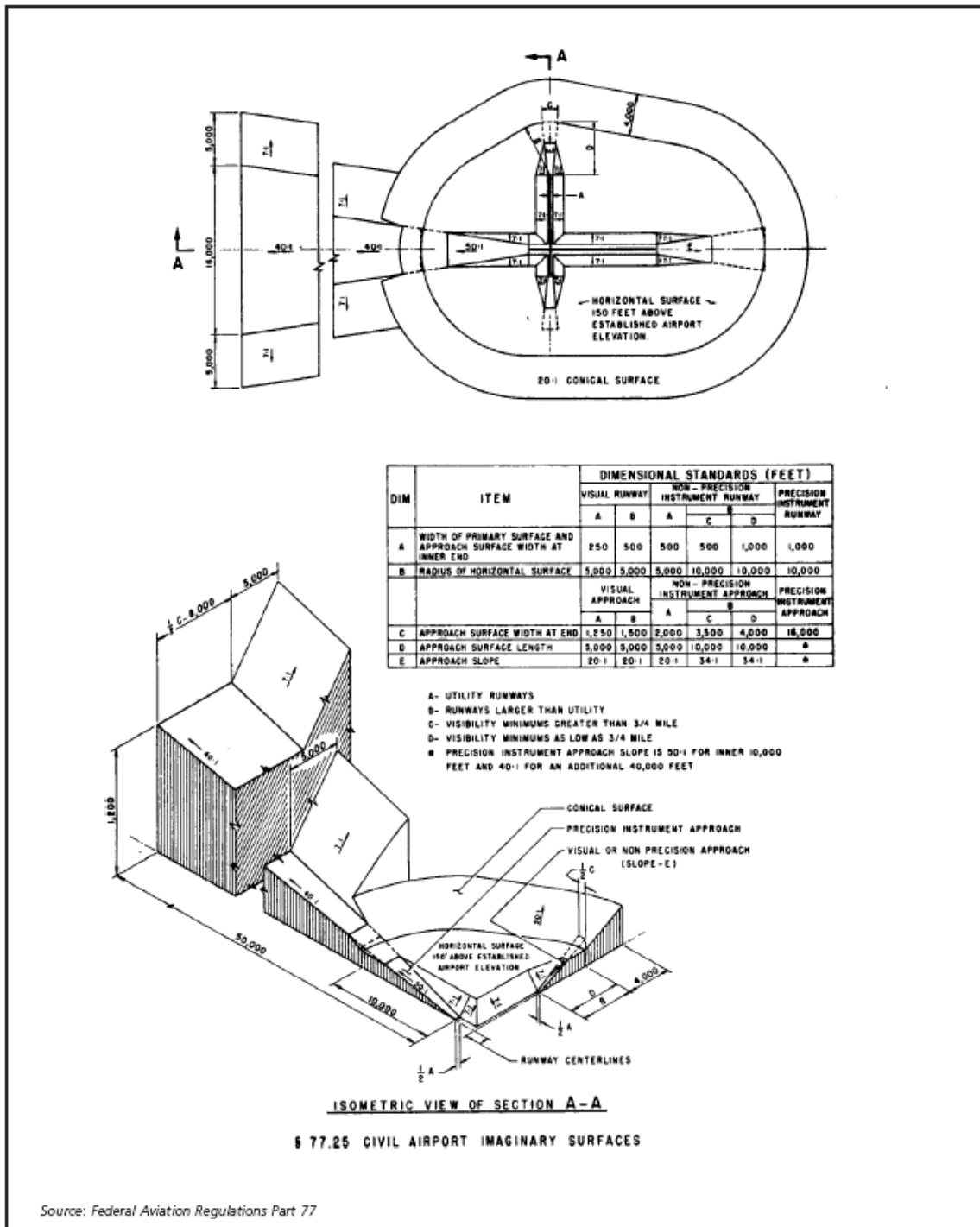

Source: Caltrans, *California Airport Land Use Planning Handbook*, January 2002.

